

Kingray

Specialists in Digital TV Distribution Solutions

MHW25FE

DIGITAL TV MASTHEAD AMPLIFIER

Thank you for selecting an Australian designed and built masthead amplifier.

This Kingray masthead amplifier is engineered to provide low band VHF plus 4G LTE & 5G filtering to maximise interference rejection.

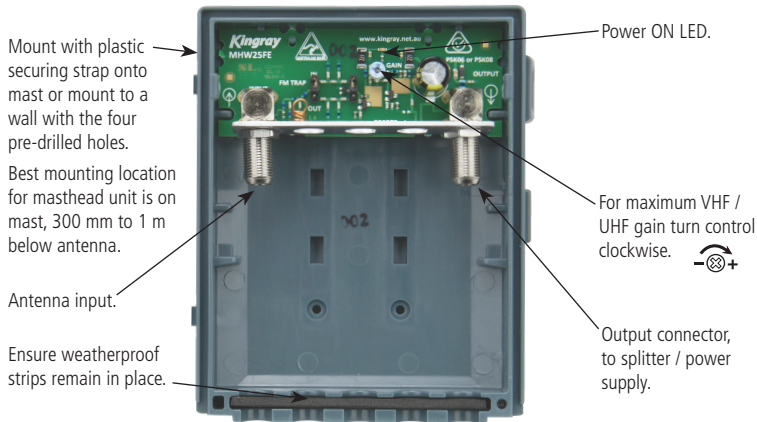

INSTALLATION

The Kingray masthead amplifiers have several built-in filters for interference rejection. The MHW25FE masthead amplifier includes low band filtering to eliminate interfering services below 174 MHz and 4G LTE as well as 5G filtering.

MHW25FE includes a switchable FM radio filter.

To configure the amplifier, please follow Fig.1 below.

FM filter

To eliminate FM radio interference; make sure both jumper links are on the 'FM TRAP IN' (DEFAULT).

To amplify FM radio signals, set both jumper links to 'FM TRAP OUT'.

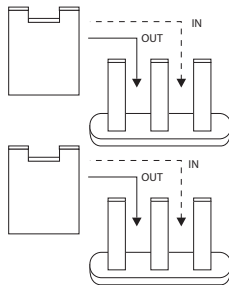
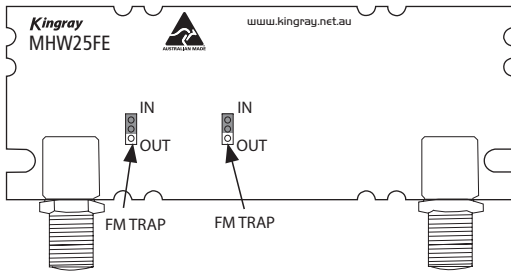
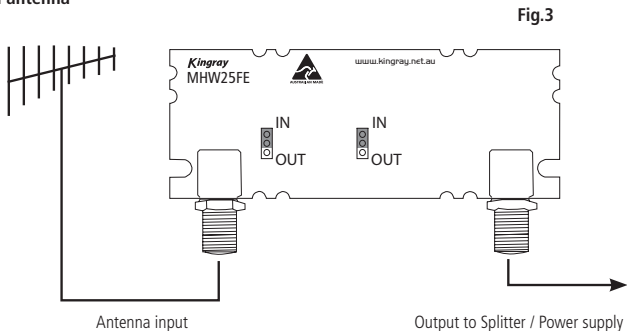

Fig.1



Connection diagram

Combination antenna



Separate antennas with external diplexer

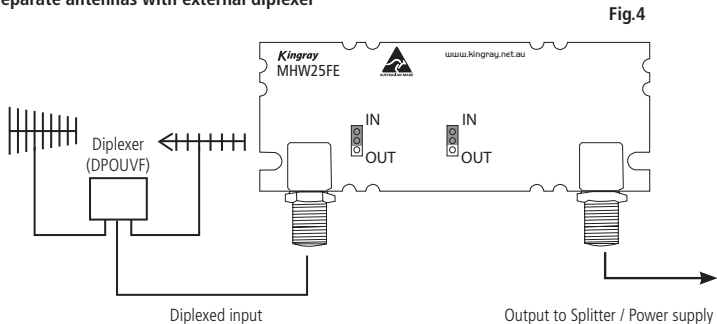

POWER SUPPLY OPTIONS

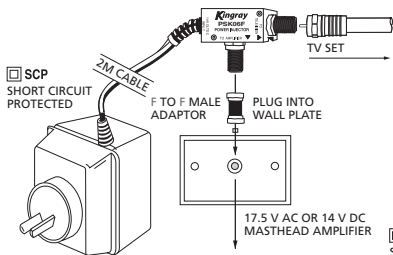

PSK06F/08F

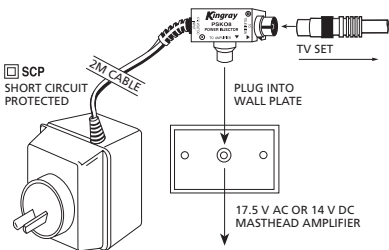

PSK06/08

TECHNICAL ADVICE

1. **Check** there is no earth braid touching the centre conductor on the coaxial cable.
2. **Is there more than one outlet?** Check the splitter box, the power supply must be connected to the coaxial outlet that feeds the AC/DC leg of the splitter box to pass power to the head unit. (Check if LED is on in the amplifier).
3. **Is there now too much signal causing an overload effect?** Try turning down the gain controls on the masthead unit, or select a lower gain amplifier.
4. **There is a white line moving through the picture:** Try a PSK06 14 V DC power supply.

Please see diagrams below for installation tips.

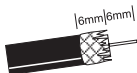

Bare back cable with a cable stripper or Stanley knife

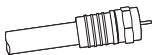

Slide on F connector and crimp or use a twist on connector



Can pivot to easily access connectors

SPECIFICATIONS

TV Frequency Range	VHF: 88-230 MHz (FM TRAP OUT) VHF: 174-230 MHz (FM TRAP IN) UHF: 520-694 MHz	Output Figure	105dB maximum DIN45004B @ (-60dB IMR)
Maximum Gain	VHF: 22-24dB UHF: 25dB	Gain Control	10dB
Noise Figure	VHF: <2dB UHF: <2.5dB	Supply Voltage	PSK08 or PSK08F (AC) PSK06 or PSK06F (DC)
FM Filter (when jumpers are set to "FM IN TRAP" position)	-25dB @ 88-108 MHz		

STANDARD COMMUNICATIONS CONTRACT WARRANTY AGAINST DEFECTS

This warranty against defects is given by GME Pty Ltd ACN 000 346 814 (We, us, our or GME). Our contact details are set out in clause 2.7. This warranty statement only applies to products purchased in Australia. Please contact your local GME distributor for products sold outside of Australia. Local distributor details at www.gme.net.au/export.

1. Consumer guarantees

- 1.1 Our goods come with guarantees that cannot be excluded under the Australian Consumer Law. You are entitled to a replacement or refund for a major failure and for compensation for any other reasonably foreseeable loss or damage. You are also entitled to have the goods repaired or replaced if the goods fail to be of acceptable quality and the failure does not amount to a major failure.
- 1.2 To the extent we are able, we exclude all other conditions, warranties and obligations which would otherwise be implied.

2. Warranty against defects

- 2.1 This warranty is in addition to and does not limit, exclude or restrict your rights under the Competition and Consumer Act 2010 (Australia) or any other mandatory protection laws that may apply.
- 2.2 We warrant our goods to be free from defects in materials and workmanship for the warranty period (see warranty table) from the date of original sale (or another period we agree to in writing). Subject to our obligations under clause 1.2, we will at our option, either repair or replace goods which we are satisfied are defective. We warrant any replacement parts for the remainder of the period of warranty for the goods into which they are incorporated.
- 2.3 To the extent permitted by law, our sole liability for breach of a condition, warranty or other obligation implied by law is limited

- (a) in the case of goods we supply, to any one of the following as we decide -
- (i) the replacement of the goods or the supply of equivalent goods;
 - (ii) the repair of the goods;
 - (iii) the cost of repairing the goods or of acquiring equivalent goods;
- (b) in the case of services we supply, to any one of the following as we decide -
- (i) the supplying of the services again;
 - (ii) the cost of having the services supplied again.
- 2.4 For repairs outside the warranty period, we warrant our repairs to be free from defects in materials and workmanship for three months from the date of the original repair. We agree to re-repair or replace (at our option) any materials or workmanship which we are satisfied are defective.
- 2.5 We warrant that we will perform services with reasonable care and skill and agree to investigate any complaint regarding our services made in good faith. If we are satisfied that the complaint is justified, and as our sole liability to you under this warranty (to the extent permitted at law), we agree to supply those services again at no extra charge to you.
- 2.6 To make a warranty claim you must before the end of the applicable warranty period (see warranty table), at your own cost, return the goods you allege are defective, provide written details of the defect, and give us an original or copy of the sales invoice or some other evidence showing details of the transaction.
- 2.7 Send your claim to:
GME Pty Ltd.
17 Gibbon Rd, Winston Hills, NSW 2153 Australia.
Tel: (02) 8867 6000, Fax: (02) 8867 6199
Email: servadmin@gme.net.au

2.8 If we determine that your goods are defective, we will pay for the cost of returning the repaired or replaced goods to you, and reimburse you for your reasonable expenses of sending your warranty claim to us.

3. What this warranty does not cover

- 3.1 This warranty will not apply in relation to:
- (a) goods modified or altered in any way;
 - (b) defects and damage caused by use with non Standard Communications products;
 - (c) repairs performed other than by our authorised representative;
 - (d) defects or damage resulting from misuse, accident, impact or neglect;
 - (e) goods improperly installed or used in a manner contrary to the relevant instruction manual; or

(f) goods where the serial number has been removed or made illegal.

4. Warranty period

- 4.1 We provide the following warranty on GME and Kingray products. No repair or replacement during the warranty period will renew or extend the warranty period past the period from original date of purchase.

Product Type	Warranty Period
Kingray Masthead Amplifiers	3 years



ISO 9001:2015
AU9710906
List of certified
characteristics available
at www.sgs.com



1300 463 463

➤ kingray.net.au

A division of GME Pty Ltd.

Head Office: PO Box 96, Winston Hills, NSW 2153, Australia.

New Zealand: PO Box 58446 Botany, Auckland, 2163, NZ. T: (09) 274 0955.

All other international enquiries email: export@gme.net.au

Drawing No: 46360-3
Part No: 310561